



Drum and Can Handling & Beverage Trucks
Pages 57 - 61



Catalog No. 2010

Phone: (800) 336-4986 www.PucelEnterprises.com Fax: (216) 881-6731

© 2010 Pucel Enterprises, Inc.



**1,000 LB
CAPACITY**



CS Series - Corner Caster Shoes - Ideal for making wood pallets or boxes portable at low cost. Shoes slide under corners.

Can be bolted, screwed, or nailed permanently. Constructed of 12 gauge steel. Set of 4

■ **Dimensions:** 8" x 8". 5¼" overall height. 2" flange, with 7/16" holes for mounting ■ **Casters:** (4 swivel) 3" x 1¼" semi-steel or hard rubber
 ■ **Capacity:** CS-3R rubber; 1,000 lbs. CS-3S steel; 1,200 lbs ■ **Weight:** CS-3R 15 lbs., CS-3S 17 lbs.

Casters

Quality Casters - For original specification or replacement. Casters equipped with zerk grease fittings for lubrication (except soft rubber casters). All casters available with wheel brake, four position or total locking brakes. Pucel equipment is always available with multiple caster options including wheel materials, capacities, widths, sizes, hubs & tires in pneumatic, semi-pneumatic & solid.

■ **1"¼" Polyurethane** - Highly mobile polyurethane tread on composite hub. Excellent for light & medium duty use. Non-marking, non-conductive wears well on most common surfaces. Highly durable industry standard.

■ **Semi-Steel** - High load capacity cast iron wheels on formed & welded steel legs. Longest life on concrete, although not ideal for floor protection.

■ **Mold-on Rubber** - Cushion rubber tread on cast iron hub. Offers additional floor & shock protection.

■ **Phenolic** - Provides best all-around service for heavy loads, non marking, non conductive. Resistant to oils & gasoline.

■ **Polyurethane / Cast Iron** - Extra durable polyurethane tread provides excellent wearability. Superior resistance to most chemicals. Non-marking.

	1 ¼" Polyurethane	Semi Steel	Mold-on & Rubber	Phenolic	Premium Polyurethane	Soft Rubber
3"						
4"						
5"						
6"						
8"						

Premium Casters

Quality Casters - These precision engineered casters greatly decrease rolling resistance reducing effort and risk of injury. Comprised of ball bearing swivel raceways and wheel hubs these high performance casters carry the total unit's weight on all floor surfaces. Ask your Pucel representative for details.



Drum Storage



**2,500 LB
CAPACITY**

#85C



• Shown in
Pucel orange

#85

85 Series Drum Storage Racks - These racks hold four drums in readily accessible positions. Designed for loading ease with whatever equipment you may now have. If your hoist does not travel over your rack, the 85-C model can be moved under your hoist.

- **Dimensions:** 60"W x 30" D x 54"H.
- **Casters:** 85-C; 6" x 2" semi steel casters (2 rigid, 2 swivel).
- **Capacity:** 2,500 lbs. ■ **Weight:** 85, 180 lbs. 85C, 198 lbs.



EBR-18CR



EBR-18C

EZY - Down Drum Cradles - These heavy duty drum cradles easily position drums from vertical to horizontal position. break the heaviest loaded drums from a vertical to a horizontal position. EBR-18CR features rollers to mix drum contents. Casters provide ease in rotating and positioning the drum while the drum is on the cradle.

- **Dimensions:** 31"W x 18 1/4" D x 18" H
- **Casters & Wheels:** 2 3" semi-steel swivel casters, and 2 3" semi-steel wheels.
- **Capacity:** 700 lbs. ■ **Options:** Extra #18 Handle

EBR Series - EZY Down Drum Cradles

Model	Features	Wt.
EBR-18C	Casters	34
EBR-18CR	Rollers/Casters	36



DS-4

DS Series - Drum Storage Racks -Holds four or six drums in readily accessible positions. Designed for loading ease from front or back. Can be moved with fork lift fully loaded. Pads on the bottom legs protect floors.

DS Series - Drum Storage Unit

Model	Drum Cap.	W	D	H	Wt.
DS-4	4	60"	36"	48"	120
DS-6	6	84"	36"	48"	200

VDU-10 - Heavy Duty Drum Stacking Units - Each unit stacks two drums horizontally. Maximum number of units to be stacked vertically is four. There is a four-way access by fork trucks.

- **Dimensions:** 44 1/4"W x 30"D x 13"H.
- **Capacity:** 1,500 lbs. ■ **Weight:** 84 lbs.

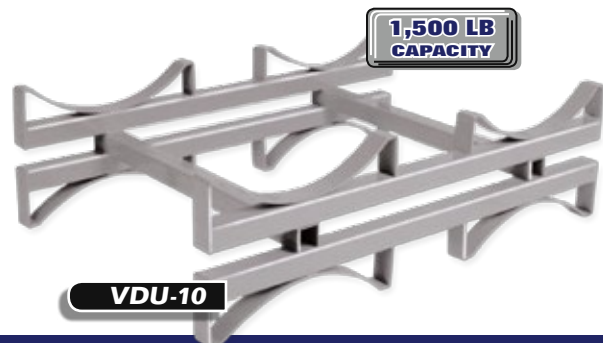

**1,500 LB
CAPACITY**

VDU-10



#81



#82G



#82



#81G



#75

AD, #70 & #80 Series - Dollies

Model	Overall Dia.	I.D.	Finish	Wt.
AD-15	Adj.	Adj.	Paint	23
AD-23	Adj.	Adj.	Paint	30
#75	24½"	24"	Paint	19
#76	19½"	19"	Paint	15
#81	24½"	24"	Paint	32
#81-G	24½"	24"	Galv.	32
#82	30½"	24"	Paint	25
#82-G	30½"	24"	Galv.	25
#83	24½"	19"	Paint	22
#83-G	24½"	19"	Galv.	22

#75 - #83 Series - Drum Dollies - Large size easy rolling casters permit quick, safe transportation of even the heaviest loaded drums. 24" diameter holds standard 55 gallon drums or other similar size containers. 19" diameter for 30 gallons or smaller containers. Galvanized finish for institutional, food processing and sanitary use. Floor clearance 4" on all models. 2" sides on #82 and #83.
 ■ **Casters:** (4 swivel) 3" x 1¼" semi-steel or rubber.
 ■ **Capacity:** 1,000 lbs.



AD-23

AD Series - Drum Dollies - Adjusts to fit your requirements. For round, square, rectangular or any irregular shaped container. AD-15 adjusts from 14¼" to 19¼". AD-23 adjusts from 23½" to 36½".
 ■ **Casters:** (4 swivel) 3" x 1¼" semi-steel or rubber
 ■ **Capacity:** 1,000 lbs.



LBR-909

LBR-909 - Low Drum Dolly Truck - This low drum truck has a steel tubular T handle. The swivel caster enable excellent maneuverability. The low profile allows easy loading and unloading. Handles 24" diameter drums. LBR-909H Unit with hinged handle.
 ■ **Dimensions:** 28"W x 33"H 1½" low underslung, 8" above floor.
 ■ **Casters:** One 3" hard rubber swivel & 2 6" x 2" phenolic wheels.
 ■ **Capacity:** 800 lbs. ■ **Weight:** 45 lbs.
 ■ **Options:** Hinged handle.



DT-25

DT-25 - Drum Dolly Truck - For transporting drums or other containers. Bracket on handle for holding cable or hose. Accessory box welded to handle for storage of tools and parts.
 ■ **Dimensions:** Accessory box size 6"W x 21"L x 12"H. Deck size 25"W x 25"L x 2"D.
 ■ **Casters:** 2 rigid, 2 swivel 5" x 2" semi-steel or phenolic.
 ■ **Capacity:** 2,000 lbs. ■ **Weight:** 63 lbs.



#71

#71 & #73 - High Drum & Can Dollies - These raised dollies provide a platform to gravity fill buckets and pails. They take up less space than drums in a horizontal position. # 71 designed for 55 gal. drums. #73 perfect for 30 gal. drums.
 ■ **Dimensions:** #71 ; 24" W. at the top, 30" at bottom, 19½" H. #73 ; 19" W at the top, 21" at bottom, 19½" H.
 ■ **Casters:** 4 swivel 3" x 1¼" rubber or semi-steel casters.
 ■ **Capacity:** Rubber casters 700 lbs., semi-steel 900 lbs. ■ **Weight:** 44 lbs.

Drum Lifters, Grips & Hooks



#80 Drum Up-Ender - Tilts drums from horizontal to vertical position with ease, speed & safety. Gives maximum leverage for lifting even the heaviest loaded drums. ■ **Weight:** 12 lbs.



VH-100 Drum Lifter - Lifts from any angle. Load can be balanced. Easily adapted to lift objects of all shapes or lengths. Automatic "upsetting" of containers by adjusting sliding hoist collar. Holds rigidly even when load sways. Adjustment between jaws 16" minimum to 40" maximum. ■ **Capacity** 1,000 lbs. ■ **Weight:** 24 lbs.



#24, #25, #26 & #210 - Easy handling by one person. In seconds the hooks can be slid on and tightened into place. Removes just as easily, no wrenches required. No. 210 Double Fork Hook has maximum openings, which permit an outside fork spread of 20-3/4". ■ **Capacity:** Single fork - 3,000 lbs, Double fork - 4,200 lbs.

Fork Swivel Hooks

Model	Frame	Opening	Weight
#24	Single	2" x 4"	17
#25	Single	2" x 5"	18
#26	Single	2" x 6"	19
#210	Double	2" x 10"	50

750 LB CAPACITY



#84 Drum Sling - Lifts drum horizontally. The harder the pull, the tighter the grip on the drum. Use the drum sling to load your Pucel drum rack. ■ **Capacity:** 750 lbs. ■ **Weight:** 11 lbs.



2,000 LB CAPACITY



#235 Vertical Drum Lifter - For open or closed drums used with fork trucks, chain falls, and hoists. Fast turning crank handle to lock upper jaw to drum top. Holds drum rigidly, even when swaying or when bumped. Lifter moves 55 gallon, 30 gallon, and smaller steel drums. ■ **Capacity:** 2,000 lbs. ■ **Weight:** 32 lbs.

800 LB CAPACITY



#100 Barrel & Drum Truck - Tubular construction with ball bearing mold-on rubber wheels, absorb shock, provide easy handling and quiet operation. Polymer grip handles. Balanced load exerted on the axle, bearings and wheels, and off the operators arms and shoulders. ■ **Dimensions:** 42" H, 20" W, Toe Plate 5" x 19" ■ **Wheels:** 8" x 2" mold-on rubber wheels ■ **Capacity:** 800 lbs. ■ **Weight:** 58 lbs.

Hand Trucks

800 LB CAPACITY

MEDIUM DUTY

HEAVY DUTY



#89



#90, 91



#92, 93



#98

#96 includes chain & storage tray



#96

#80 - #90 Series Hand Trucks - Tubular construction with curb jumper, all edges rounded smooth for appearance and safety, ball bearing rubber wheels, absorb shock, provide easy handling and quiet operation. Plastic grip handles. Balanced load exerted on the axle, bearings and wheels, and off the operators arms and shoulders. Specify color when ordering.

• Shown in Pucel dark green, dark blue, putty, & red



#300, 311

#80 & 90# Series - All Purpose Hand Trucks

Model	H	W	Toe Plate	Cap.	Wheels	Wt.
#89	46"	18"	8" x 14"	250	8" x 1 3/4" Semi-Pnue.	27
#90	48"	18"	8" x 14"	650	10" x 2 3/4" Semi-Pnue.	37
#91	48"	20"	8" x 14"	500	10" x 3 1/2" Pnue.	40
#92	48"	18"	8" x 14"	650	10" x 2 3/4" Semi-Pnue.	30
#93	48"	20"	8" x 14"	500	10" x 3 1/2" Pnue.	42
#96	45"	33"	13" x 25"	650	12" x 3" Semi-Pnue.	52
#98	43"	18"	9" x 18"	800	8" x 2" Mold-On	55

#300 Series - Premium Beverage Trucks

Model	H	W	Toe Plate	Cap.	Wheels	Wt.
#300	53 1/2"	16"	8 1/4" x 10 1/2"	650	10" x 2 3/4" Semi-Pnue.	36
#311	53 1/2"	18"	8 1/4" x 10 1/2"	500	10" x 3 1/2" Pnue.	35

#300 Series Beverage Truck - Easy to push, even under the heaviest loads. Keeps load on the axle and off operators arms. Designed for rugged use on pavement and curbs. Moves up to six cases of small and large containers. Floating axle absorbs shock. Toe plate gives added strength and adequate load bearing area. Narrow tubular frame with polymer hand grips.